



CANISTER

Safe change filter housing

Product	CANISTER
Mechanical resistance	+/-5 kPa according to ANSI-ASME 510-1980
Operating temp.	according to technical features of filter (except for TB –TC filters)

Canister safe change filter housings are used for the tight housing of filters used to filter air containing noxious, toxic, radioactive substances, etc. They are especially used in industrial plants, laboratories, and process applications. Their main feature is to allow the maintenance personnel to safely replace the exhausted filters, both absolute and activated carbon. In fact the operator never touches the filters because they are insulated inside a protection bag where they are sealed and then disposed of. This operation is also very safe for the surrounding environment.

The new filters are then handled without any direct contact. They are pulled out of their protection bags (bag-in, bag-out procedure). Canister containers are constructed of strong galvanized sheet steel, welded, externally and internally varnished with decontamination paint (V1.Z); on request we can also supply the product with an AISI 304 (SS) stainless steel structure. They are fitted with a side inspection door with sealing handles, there are also pressure ports, centering devices and filtration element locking and other features to guarantee extremely safe use and operation.

Applications Canister containers are used in industrial plants, processing plants and laboratories where the air to be filtered is filled with gas or noxious or toxic substances, or it is polluted by radioactive particles (radioisotope). Their use is also foreseen in strategic applications and civil structures whose particular importance make them a potential target for chemical/biological threats (embassies, government offices, etc.).

Installation Canister containers are suitable for direct duct installation using the flanges they are fitted with. In this case the container is connected upstream of the polluted air exhaust duct and downstream of the filtered air outlet duct. Alternatively, Canister containers can be installed on proper collectors, according to the air volumes to treat, and then connected to polluted air exhaust ducts and clean air supply ducts.

Type	Sizes (mm)			Filter sizes (mm)						
	CAN	A	B	C	A	B	C			
42	449	x	810	x	431	305	x	610	x	150
4	754	x	810	x	431	610	x	610	x	150
52	449	x	810	x	573	305	x	610	x	292
5	754	x	810	x	573	610	x	610	x	292
4 BF	754	x	1620	x	431	610	x	610	x	150
5 BF	754	x	1620	x	573	610	x	610	x	292
CAN BAG	42 - 4 - 52 - 5									
CAN RING	42 - 4 - 52 - 5									

*1 m³/s x 10⁻³ = 1 l/s

Size

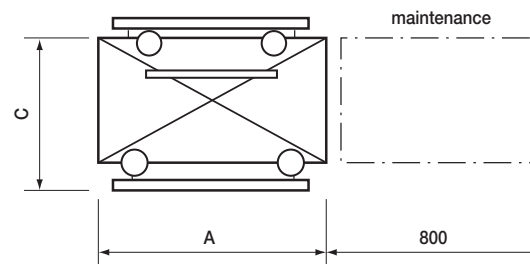

One Front Version

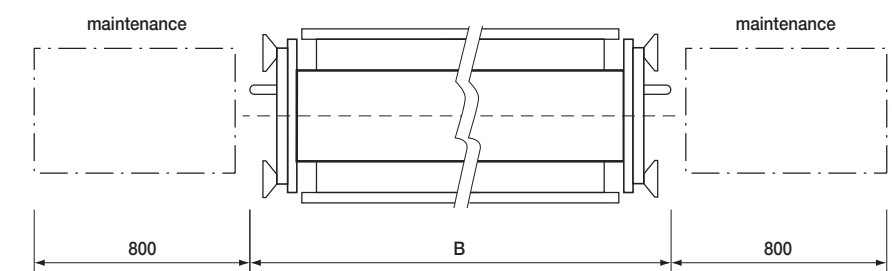

Double Front version (BF)

Sizes (mm) Weight (Kg) Canister

CAN	H	Weight
42	431	32
4	431	68
52	573	36
5	573	45
4 BF	431	68
5 BF	573	85



CANISTER system

Standard formats of the low pressure system

The overall dimensions of the Canister System can easily be calculated as follows:

- A) define the number and type of filtering stages that form each housing
- B) divide the total air flow rate by the unit one of the housing (which is the unit rate of the filter) to obtain the number of housing. This is how you can determine the size of the collectors (number of outlets).
- C) By using the chart of the "Standard Collectors" you can find the missing measurements to define the total height (height of housing + lower collector height + upper collector height).
- D) by using the chart you can find the height of the Housing, the width of the System and the free space required for maintenance operations.

Lower heights or special types must be directly evaluated by our technical Office.

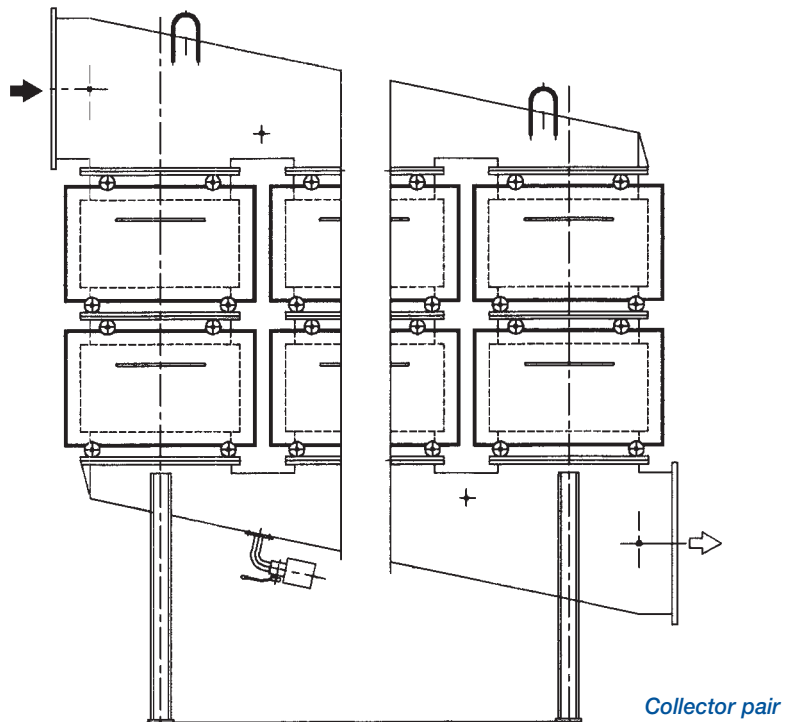

options request

- Vacuum breaker
- Tightness damper DIN 1946-69 part 4
- Reading systems (outlet ΔP)
- DOP probe

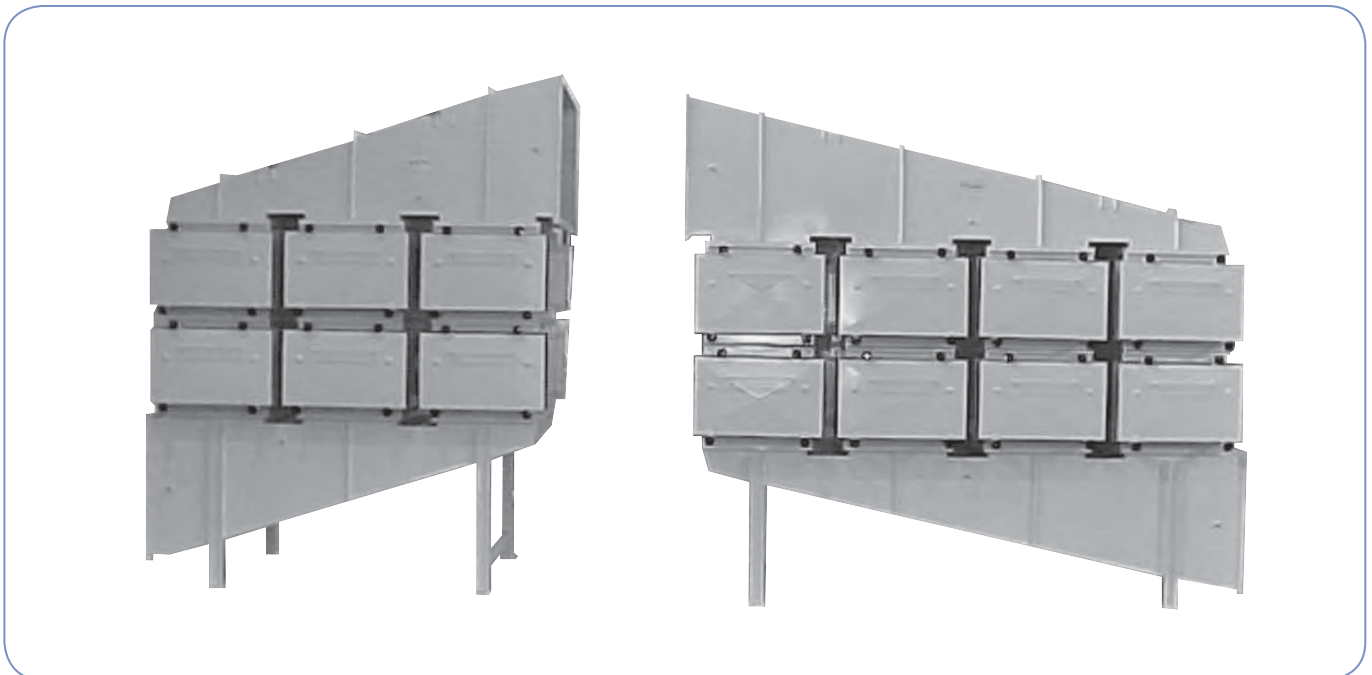

CANISTER system

Collectors sizes and weights

System plan

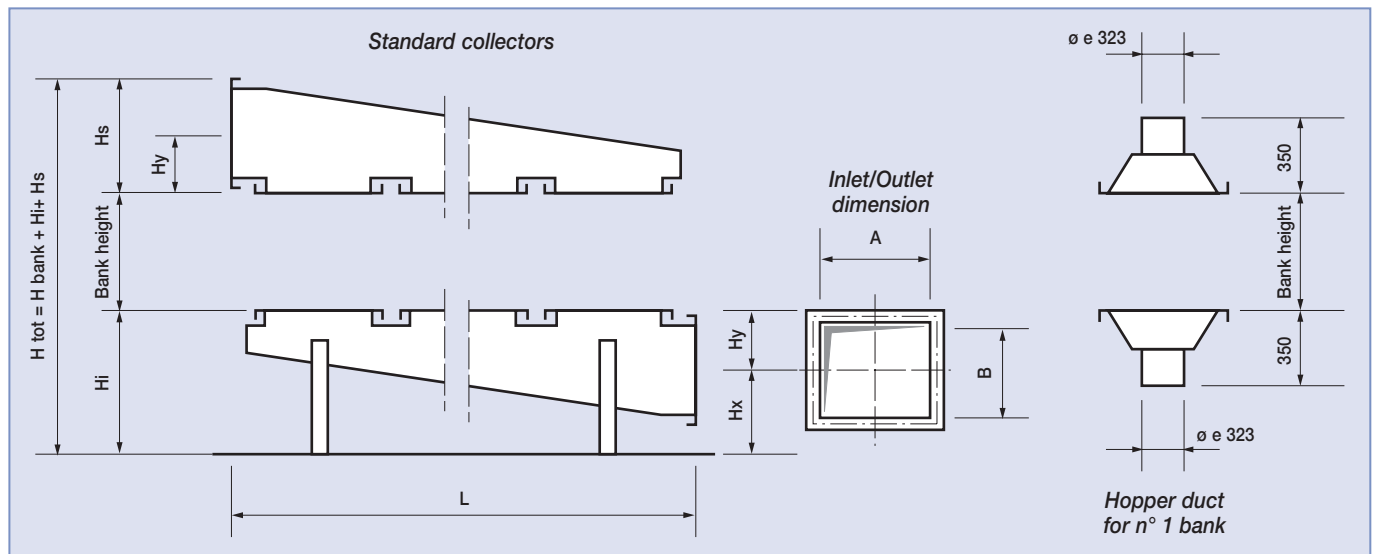

Standard air flow rates

	ONE-FRONT					DOUBLE-FRONT			
	1	2	3	4	5	2	3	4	5
	Banks number								
A	ø e 323	558	558	558	558	1186	1186	1186	1186
B	ø e 323	254	406	558	558	254	406	558	558
Hx	---	280	350	430	430	280	350	430	430
Hy	---	180	255	335	335	180	255	335	335
Hi	---	460	605	765	765	460	605	765	765
Hs	---	350	500	655	655	350	500	655	655
L	---	1670	2475	3280	4085	1670	2475	3280	4085
Weight	20	120	180	270	320	250	370	530	630

Oversize air flow rates

	ONE-FRONT				DOUBLE-FRONT			
	2	3	4	5	2	3	4	5
	Banks number							
A	558	558	580	558	1186	1186	1186	1186
B	558	800	1000	1200	550	800	1000	1150
Hx	420	540	640	740	420	540	640	750
Hy	335	455	555	655	330	455	555	630
Hi	755	955	1195	1395	750	995	1185	1345
Hs	660	900	1100	1300	650	900	1100	1250
L	1670	2475	3280	4085	1670	2475	3280	4085
Weight	170	250	300	500	230	360	520	680



CANISTER system

Filter replacement diagram with Bag-in/Bag-out procedure

1. First filter

- Put filter in container and tighten the levers
- Fix the PVC bag on the collar with fastening ring

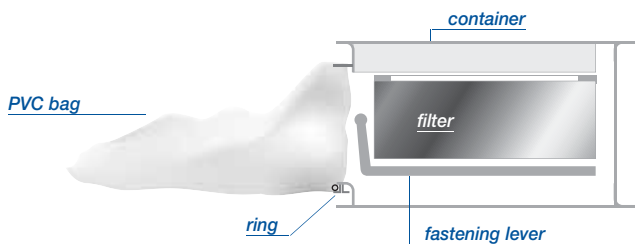

2. Operating position

- Fold PVC bag positioning it in front of the filter
- Close the lid and tighten the locking handwheel

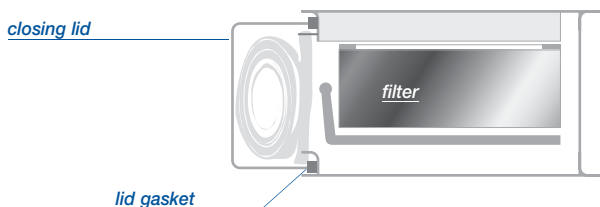

3. Changing filter

- Switch off the fan
- Close the dampers up- and downstream (if installed)
- Bring the system to room pressure using the vacuum breaker (if installed)
- Remove the handwheels and the lid
- Lower the locking levers
- Roll out the bag and remove the dirty filter, put it on a surface at the same level of the container

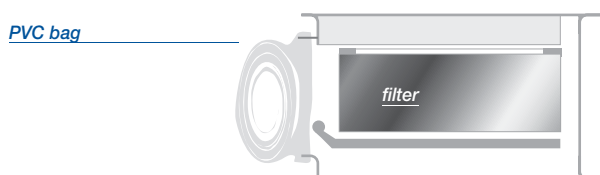

4. Bag sealing procedure

- Flatten out the bag, eliminate all folds. Seal bag using a thermal-welding pliers, double seal and cut between seals.

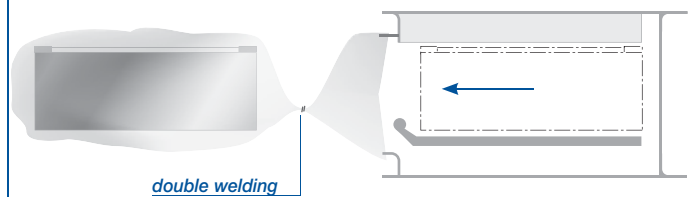

5. Removing the residues of the old bag

- Put in new bag, after installing the new filter fixing it with the fastening ring inside the collar.
- Remove the residue of the bag with relating ring from the collar and put it behind the new filter using the new bag as a glove
- Afterwards move the elastic of the new bag from the inner seat of the outer collar.

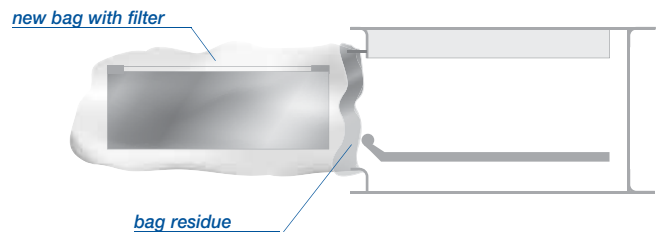

6. Inserting the filter

- Push the filter in the container and lock the fastening levers
- Roll up the new bag with the residue of the old bag and put it in front of filter.
- Put on the lid and tighten the locking handwheels
- Close the vacuum breaker (if installed)
- Open the dampers closed previously (if installed)
- The system is operative again

