

MULTIMOD

In-line housings for filters G1 – F9

Product	MULTIMOD
Structure	Galvanized steel
Locking	AISI 304 stainless steel double eccentric lever
Door	Galvanized steel with edge and AISI 304 stainless steel locking
Gasket	Closed cell neoprene on door ledge
Flanges	Air inlet/outlet side

Multimod containers are modular and versatile systems that house cell filters, with soft and rigid pockets, and activated carbon filters mod. CAB.

They are very easy to install and for this reason they are used in all those cases where it is necessary to insert a single or multiple (with a series of filters) filtration stage to obtain filtration levels from G1 to F9.

Multimod containers are constructed of galvanized sheet steel and are fitted with an access door with eccentric locking cam, with a closed cell neoprene gasket on the ledge. The filter is locked by a double eccentric lever. Perforated flanges are fitted at air inlet/outlet.

Applications Multimod containers can be applied in all civil and industrial systems where rigorous and reliable air filtration is required. They are very suitable for application in restructuring operations where, by separating the filtration section from the ventilation one, you can make the best use of space. The application of Multimod containers upstream of the air diffusers, guarantees the quality of all the air treated to reach very high air cleanness conditions.

Installation Multimod containers are used in horizontal air flow installations; the air inlet side is the same where the filter creates the tightness closing. The perforated flanges make installation easier. You can also make filtration walls with one or more overlapping modules, up to maximum of three. Except for specific requests, the walls are already assembled in one piece. In the case of supply of modules to install on site, special connection pieces are supplied.

Type	Sizes (mm)			Pitch fori	Holes n°	Weight Kg
	A	B	C			
MD 52	690	x 375	x 585	172/211	12	17
MD 5	690	x 690	x 585	172	16	22
2 MD 5	690	x 1380	x 585	172	32	46
3 MD 5	690	x 2070	x 585	172	48	70
MD 8	998	x 690	x 585	172/211	28	28
MD 5 BP	1304	x 690	x 585	172	32	27
2 MD 5 BP	1304	x 1380	x 585	172	64	58
3 MD 5 BP	1304	x 2070	x 585	172	96	90

*1 m³/s x 10⁻³ = 1 l/s

N.B. Specify the filter model to choose the equipment

For actual sizes please refer to our Pricelist

Codes for MULTIMOD "MD 5" versions

Versions	PREFILTER			FILTER		
	Sizes (mm)			Sizes (mm)		
A	---	---	---	610 x 610 x 150		
B	610 x 610 x 48			610 x 610 x 150		
C	---	---	---	610 x 610 x 292		
D	610 x 610 x 48			610 x 610 x 292		
E	610 x 610 x 98			610 x 610 x 292		
F	---	---	---	595 x 595 x 292 / 635		rigid or soft pockets
G	595 x 595 x 23			595 x 595 x 292 / 635		rigid or soft pockets
H	595 x 595 x 48			595 x 595 x 292 / 635		rigid or soft pockets
I	595 x 595 x 98			595 x 595 x 292 / 635		rigid or soft pockets
L	---	---	---	600 x 600 x 300 / 400		activated carbon with cartridges
M	610 x 610 x 48			600 x 600 x 300 / 400		activated carbon with cartridges

Size

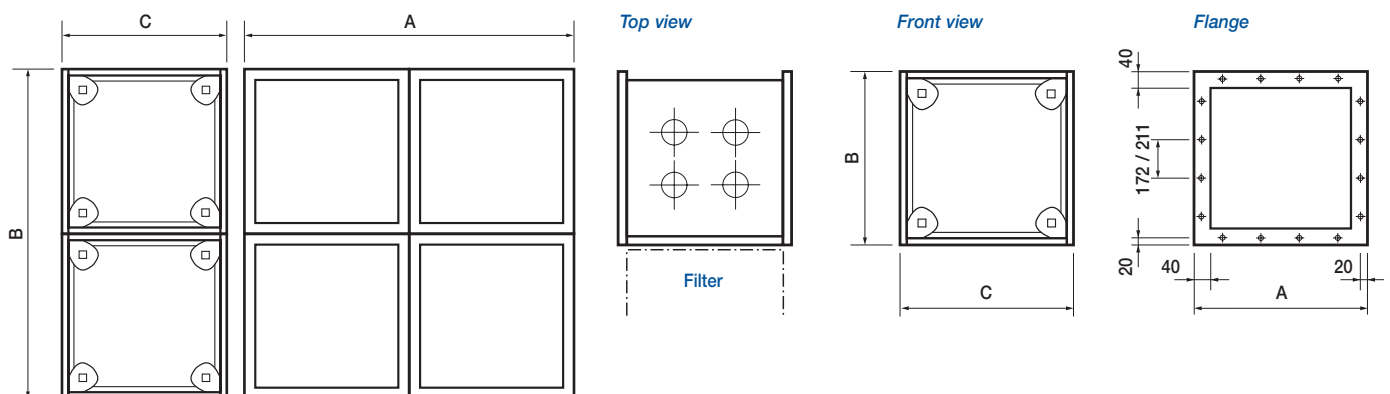

2 MD 5BP system

