

BIJLAGE: CLEANROOMROOSTERS & FILTERS

INTERLAND TECHNIEK





Clean air diffusers

RA - DA
RA - DS
RA - DFA

Application

The clean air diffusers type RA are used for rooms requiring hygienic air conditions, e. g.:

Ventilating plants in accordance with DIN 1946 Part 4

- operating rooms and preparation rooms
- intensive-care units

Clean rooms in

- medical technology
- pharmaceutical industry
- food industry
- semiconductor technology

Clean air diffuser components

The clean air diffuser assembly comprises the following components:

Mechanical filter housing

The housing is available in four sizes with horizontal or vertical inlet spigot in three designs with different filter systems.

Size	Plenum box dimensions	Inlet spigot DN
1	305x305 mm	160
2	457x457 mm	200
3	575x575 mm	200/250
4	610x610 mm	250

Filter cells

The filter cells are supplied as class H11, H13 and H14 HEPA filters and class U15 ULPA filters. Class F9 fine filters are available as preliminary filter or return air filter. The standard filter height is 78 mm or 130 mm for filters with gel sealing. Other filter heights are available on request.

Diffuser

Depending on the rate of air change, three types of diffusers guarantee the desired low airflows within the occupied zone.

Rate of air change h^{-1}	Type of diffuser
≤ 15	Swirl diffuser DA
≤ 25	Swirl diffuser DS
≤ 60	Swirl diffuser DFA

Flow patterns of the diffusers



Swirl diffuser DA

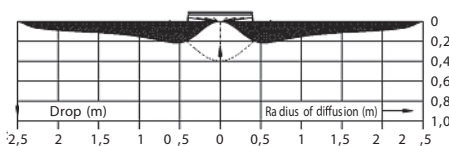

Swirl diffuser DS

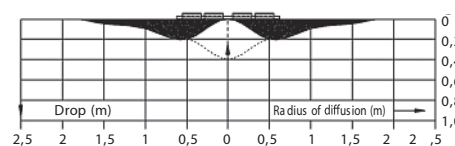

Swirl diffuser DFA

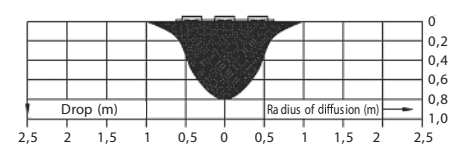

Clean air diffusers

Filter housing

Table of contents

	page
General, function, sizes and performance parameters	1
Filter housing	2-4
Filter cell	5-9
Diffuser	10
Technical data – size 1	11
Technical data – size 2	12
Technical data – size 3	13-14
Technical data – size 4	15
Tender text	16

Filter housing

Steel housing with a white (RAL 9010) decontaminable plastic coating comprising:

- Filter sealing system
- Inlet spigot
- Measuring and testing connections

Filter-sealing system

Type A:

Plenum box with flange for filter with grooved test sealing or continuous sealing (usage for filter cells up to H14 class filters)

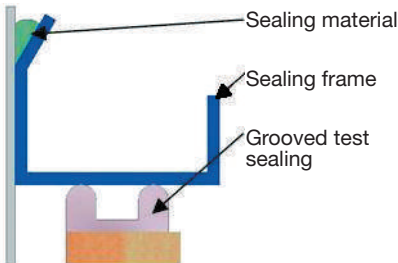

Type B:

Hollow aluminium section for flat sealing (usage for filter cells up to H14 class filters)

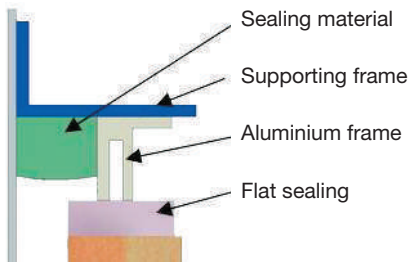

Type C:

Plenum box with Z-frame for gel sealing at the filter cell (usage for filter cells up to H14 and U15 class filters).

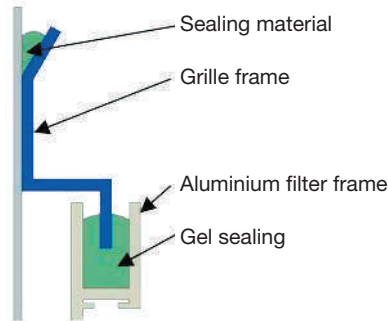

Inlet spigot

The plenum box has a standard side or top inlet circular spigot. Rectangular spigots can be fitted upon request.

The side inlet spigot can be supplied with a damper valve, which enables changing the filter while the system is running. The damper valve can also be used for balancing purposes.

The damper valve is designed for Class 4 DIN EN 1751.

Electric or pneumatic damper valves are also available on request.

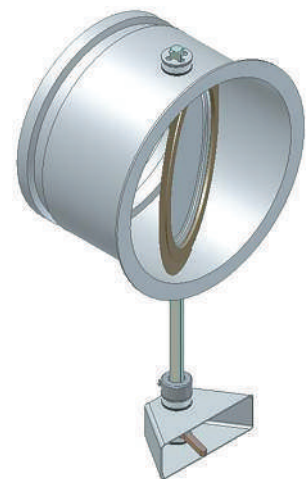
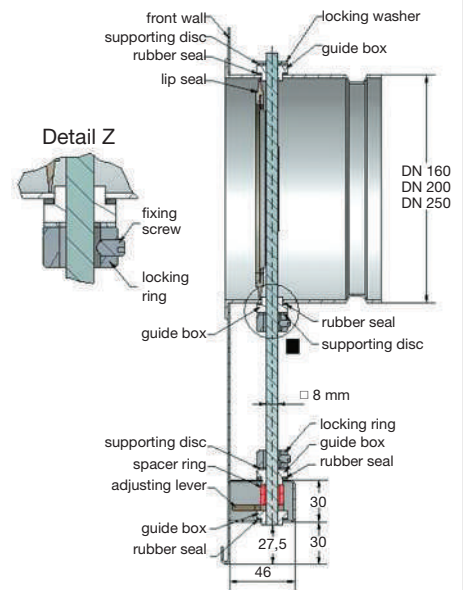

Circular damper valve

Technische Änderungen vorbehalten.

Strulik GmbH D-65597 Hünfelden
 Strulik GmbH D-47138 Duisburg
 Strulik GmbH CH-8645 Jona

Neesbacher Str. 15
 Am Alten Viehhof 7
 Eichwiesstrasse 4

Phone (0 64 38) 8 39-0
 Phone (02 03) 4 29 46-0
 Phone (+41) 552 10 09-38

Fax (0 64 38) 8 39-30
 Fax (02 03) 4 29 46-66
 Fax (+41) 552 10 09-39

Email: contact@strulik.com · technik@strulik.com
 Email: contact@strulik.com
 Email: contact@strulik.ch

www.strulik.com
www.strulik.ch

Clean air diffusers

Filter housing

Measuring and testing connections

Standard sealing test device is included for types A and B.

All filter housings are furnished with a manometer/oil mist connection with which the pressure upstream of the filter can be measured or an oil mist can be introduced when the diffuser has been removed.

Pressure connections upstream and downstream of the filter are available on request.

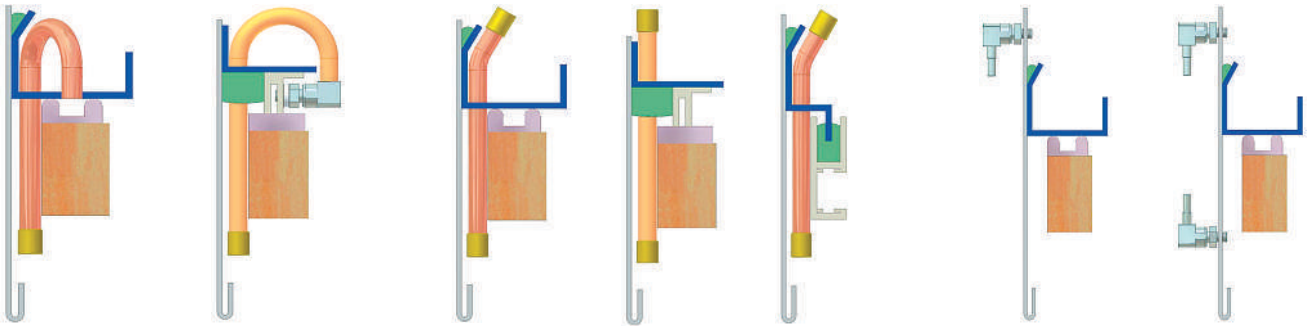

Connections for filter systems types A and B.

Connection for manometer/oil mist test for filter sealing systems A, B and C.

External connections for measuring pressure upstream of the filter or differential pressure across the filter.

Dimensions and weights

Standard type (spigot at the side) housing with circular inlet spigot **without damper valve**.

Size	Spigot DN	Dimensions (mm)				Weight (kg) ¹⁾
		A	B	H	L	
1	160	325	266	380	110	13
2	200	477	290	420	130	22
3	200	595	290	420	130	30
	250	595	315	470	152	31
4	250	630	315	470	152	34

¹⁾ The weight includes plenum box, filter and air diffuser

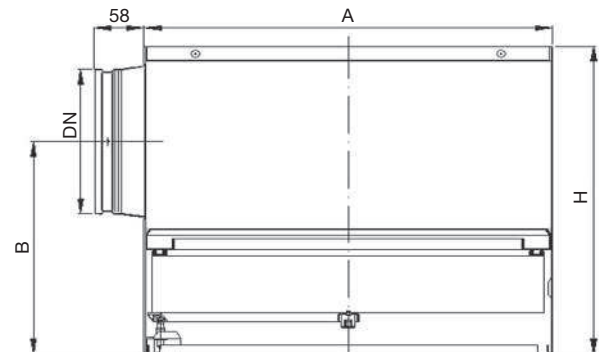

Clean air diffusers

Filter housing

Standard type (side inlet) housing with circular inlet spigot with damper valve.

Attention!

The dimensions of the box apply to the types A and B with a filter height of 78 mm. For type C with a filter height of 130 mm the height of the box increases by 50 mm.

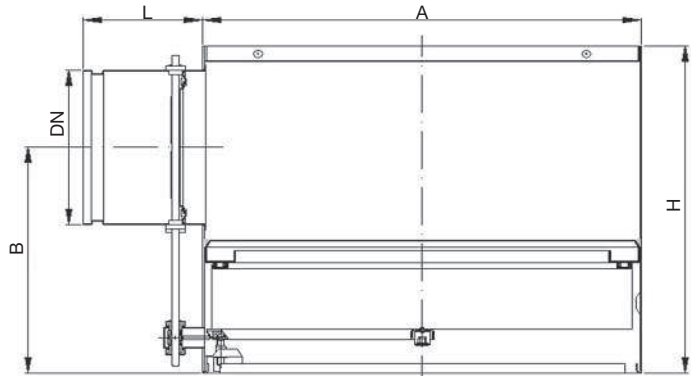

Standard type (top inlet)

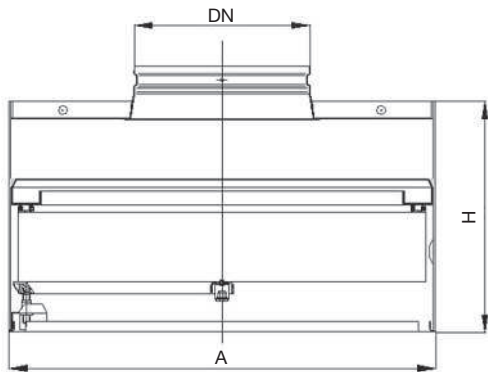

Housing with circular top inlet spigot without damper valve.

Special type (side inlet) housing with rectangular inlet spigot

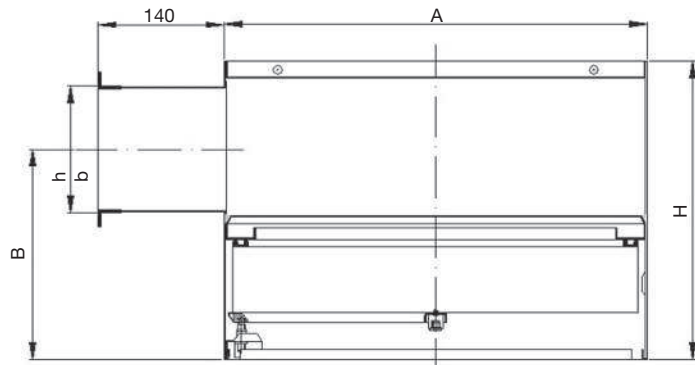

Housing with rectangular inlet spigot without damper valve.

Size	Spigot DN	Dimensions (mm)		Weight (kg) ¹⁾
		A	H	
1	160	325	260	11,5
2	200	477	260	19,5
3	200	595	260	27,0
	250	595	260	27,0
4	250	630	300	30,5

¹⁾ The weight includes the plenum box, filter and air diffuser.

Size	Spigot		Dimensions (mm)			Weight (kg) ¹⁾
	h	b	A	B	H	
1	125	300	325	234	315	11,5
2	150	400	477	247	340	22,5
3	150	500	595	247	340	29,5
4	150	550	630	247	340	33,0

¹⁾ The weight includes the plenum box, filter and air diffuser.

Clean air diffusers

Filter cells

F9 fine filter performance

Average efficiency:
 $E \leq 95\%$

F9 fine filter
 (in accordance with filter class DIN EN 779)

Filter types:
 HS-Makro-SF F9
 Mikrofil HO 78 F9

General

The F9 fine filters type HS-Makro F are robust fine dust filters that are used for high and/or variable volume flows. Typical applications are e.g.:

- Prefilter for mechanical filters
- Hospitals
- Pneumatic filtration in the industry etc.

Types

Frame:

- Fibreboard of medium density (MDV) as standard design
- Aluminium
- Stainless steel (1.43.01)

Types of sealings:

- Grooved sealing for testing the tightness of the seat

Form: 

- Flat neoprene sealing

Form: 

- Solid continuous polyurethane sealing

Form: 

Grip protection (optional):

- Grip protection on one side
- Grip protection on two sides

Separators:

- Thermoplastic (Minipleat)

Technical Data:

- Maximum temperature: 65 °C
- Maximum relative humidity: 100%

Dimensions and weights

Size	Dimensions (mm)			Weight (kg)	Nominal volume flow	
	Width	Height	Depth		(l/s)	(m³/h)
	HS-Makro-SF, depth 78 / Mikrofil HQ, depth 78					
1	305	305	78	1,5	70	250
2	457	457	78	2,5	160	560
3	575	575	78	3,4	250	900
4	610	610	78	3,5	280	1000

Initial pressure losses

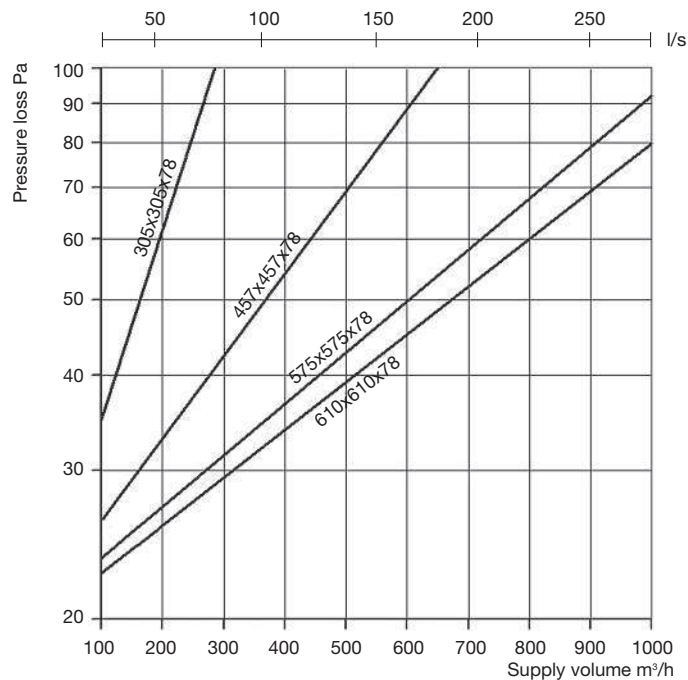

Initial pressure losses for F9 fine filters with a depth of 78 mm for the sizes 1–4. Recommended final pressure loss 300 Pa.

Clean air diffusers

Filter cells

H11 Hepa filter performance

Extraction capacity: 95%
(integral value)

H11 fine filter
(in accordance with filter class DIN EN 1822)

Filter types:
HS-Mikro-SF H11
Mikrofil HO 78 H11

General

The H11 mechanical filters are high-efficiency filters for the extraction of suspended particles such as viruses, germs, toxic dust, aerosol etc. They are used when the air has to be dust-free and germ-free. The filters can be used for both dust-laden air and clean air.

Types

Frame:

- Fibreboard of medium density (MDF) as standard design
- Aluminium
- Stainless steel (1.43.01)

Types of sealings:

- Grooved sealing for testing the tightness of the seat

Form: 

- Flat neoprene sealing

Form:  Height: 6 mm

- Solid continuous polyurethane sealing

Form:  Height: 6 mm

Grip protection (optional):

- Grip protection on one side
- Grip protection on two sides

Separators:

- Thermoplastic (Minipleat)

Technical Data:

- Maximum temperature: 65 °C
- Maximum relative humidity: 100%

Dimensions and weights

Size	Dimensions (mm)			Weight (kg)	Nominal volume flow	
	Width	Height	Depth		(l/s)	(m³/h)
HS-Mikro SF, depth 78 / Mikro HO, depth 78						
1	305	305	78	1,5	70	250
2	457	457	78	2,5	160	560
3	575	575	78	3,4	250	900
4	610	610	78	3,5	280	1000

Initial pressure losses

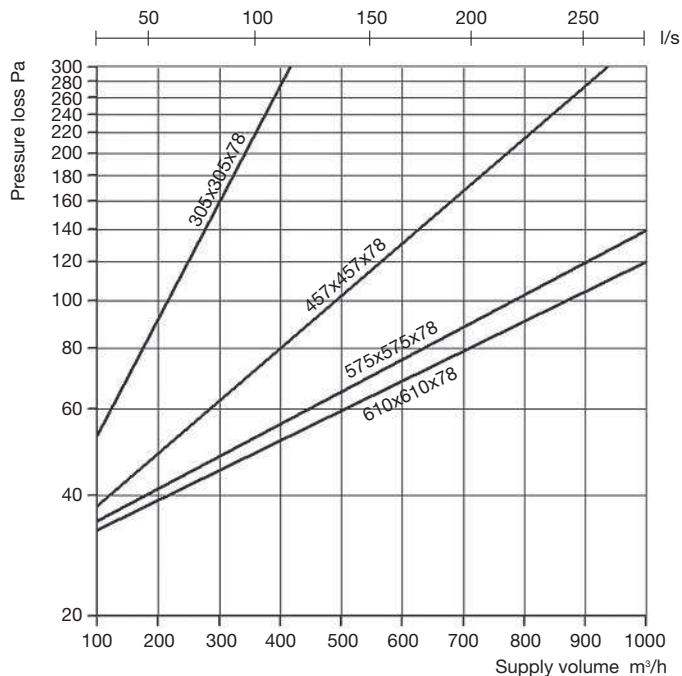

Initial pressure losses for H11 Hepa filters with a depth of 78 mm for the sizes 1–4. Recommended final pressure loss 500 Pa.

Clean air diffusers

Filter cells

H13 Hepa filter performance

Extraction capacity: 99,95%
(integral value)

H13 Hepa filter
(in accordance with filter
class DIN EN 1822)

Filter types:
HS-Mikro-SF H13
Mikrofil HO 78 H13

General

The H13 mechanical filters are high-efficiency filters for the extraction of suspended particles such as viruses, germs, toxic dust, aerosol etc. They are used when the air has to be dust-free and germ-free. The filters can be used for both dust-laden air and clean air.

Types

Frame:

- Fibreboard of medium density (MDF) as standard design
- Aluminium
- Stainless steel (1.43.01)

Types of sealings:

- Grooved sealing for testing the tightness of the seat

Form: 

- Flat neoprene sealing

Form:  Height 6 mm

- Solid continuous polyurethane sealing

Form:  Height: 6 mm

Grip protection (optional):

- Grip protection on one side
- Grip protection on two sides

Separators:

- Thermoplastic (Minipleat)

Technical Data:

- Maximum temperature: 65 °C
- Maximum relative humidity: 100%

Dimensions and weights

Size	Dimensions (mm)			Weight (kg)	Nominal volume flow	
	Width	Height	Depth		(l/s)	(m³/h)
	HS-Mikro SF, depth 78 / Mikro HO, depth 78					
1	305	305	78	1,5	70	250
2	457	457	78	2,5	170	600
3	575	575	78	3,4	270	970
4	610	610	78	3,5	305	1100

Initial pressure losses

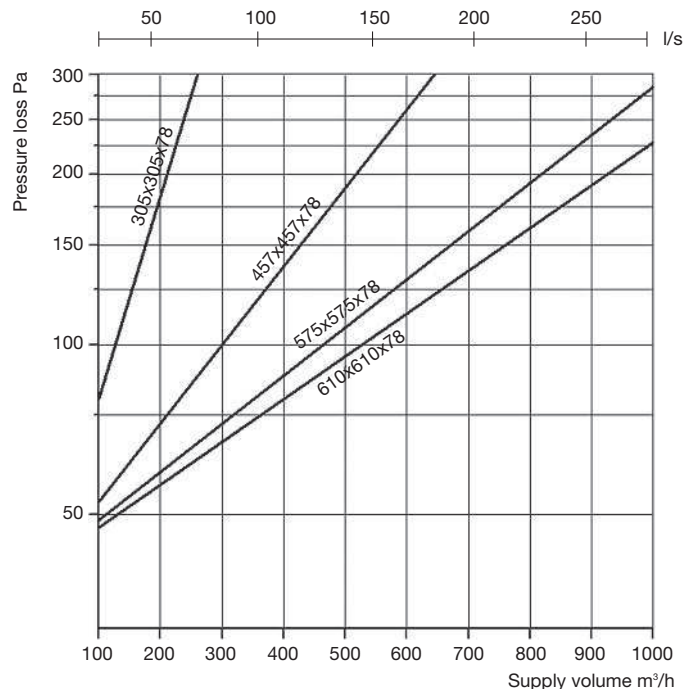

Initial pressure losses for H13 Hepa filters with a depth of 78 mm for the sizes 1–4. Recommended final pressure loss 500 Pa.

Clean air diffusers

Filter cells

H14 Hepa filter performance

Extraction capacity: 99,995%
(integral value)

H14 Hepa filter
(in accordance with filter class DIN EN 1822)

Filter types:
HS-Mikro SF H14
Mikrofil AL 68 H14
Mikrofil AL G80 H14

General

The H14 mechanical filters are high-efficiency filters for the extraction of suspended particles as for example viruses, germs, toxic dust, aerosol etc. They are used when the air has to be dust-free and germ-free. The filters can be used for both dust-laden air and clean air.

Types

Frame:

- Fibreboard of medium density (MDF) as standard design
- Aluminium
- Stainless steel (1.43.01)

Types of sealings:

- Grooved sealing for testing the tightness of the seat

Form: 

- Flat neoprene sealing

Form:  Height: 6 mm

- Solid continuous polyurethane sealing

Form:  Height: 6 mm

Grip protection (optional):

- Grip protection on one side
- Grip protection on two sides

Separators:

- Thermoplastic (Minipleat)

Technical Data:

- Maximum temperature: 65 °C
- Maximum relative humidity: 100%

Dimensions and weights

Size	Dimensions (mm)			Weight (kg)	Nominal volume flow	
	Width	Height	Depth		(l/s)	(m³/h)
	HS-Mikro SF, depth 78 / Mikrofil AL 68, depth 68 / AL G80, depth 80					
1	305	305	78/68/80	1,5	42	150
2	457	457	78/68/80	2,5	95	340
3	575	575	78/68/80	3,4	150	530
4	610	610	78/68/80	3,5	170	600

Initial pressure losses

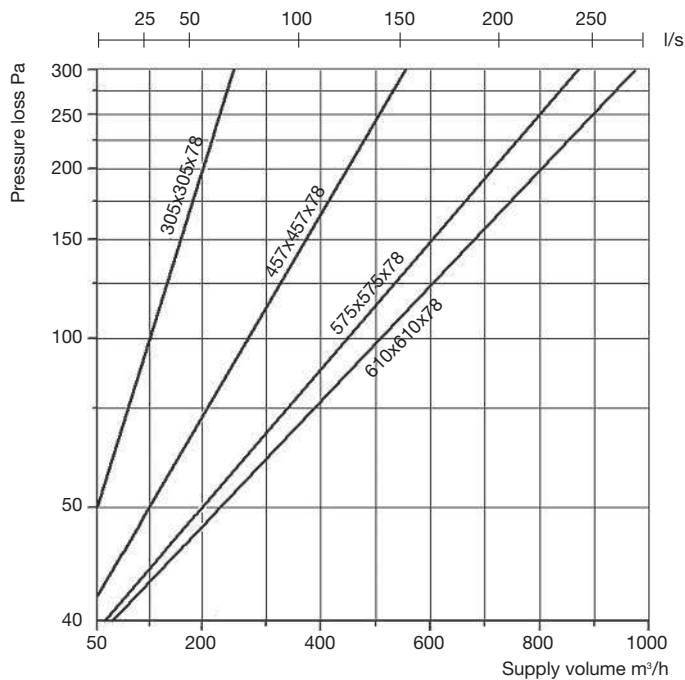

Initial pressure losses for H14 Hepa filters with a depth of 78 mm for the sizes 1–4. Recommended final pressure loss 500 Pa.

Clean air diffusers

Filter cells

U15 Ulpa filter performance

Extraction capacity: 99,9995%
(integral value)

Ulpa-Filter U15
(in accordance with filter class DIN EN 1822)

Filter types:
HS-Mikro SF U15
ALG 102 U15
AL 90 U15

General

The U15 Ulpa filters with aluminium frame are very high efficiency filters used in very sensitive regions in the pharmaceutical industry, medical service area and technology. These areas require high purity standards to comply with set standards for the products which being handled as well as protection of the work force.

Types

Frame:

- Anodized aluminium extrusion press profile

Sealing:

Filter frame with a 20 mm U profile flange, filled with as a fluid sealing.

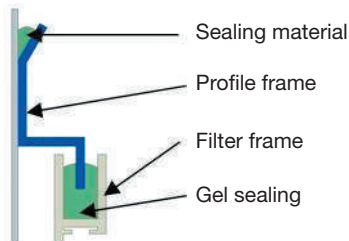

Grip protection (optional):

- Grip protection on one side
- Grip protection on two sides

Separators:

- Thermoplastic (Minipleat)

Technical Data:

- Maximum temperature: 65 °C
- Maximum relative humidity: 100%

Dimensions and weights

Size	Dimensions (mm)			Weight (kg)	Nominal volume flow	
	Width	Height	Depth		(l/s)	(m³/h)
HS-Mikro SF, depth 130 / ALG 102, depth 102 / AL 90, depth 90						
1	305	305	130/102/90	1,9	42	150
2	457	457	130/102/90	3,1	95	340
3	575	575	130/102/90	4,3	160	580
4	610	610	130/102/90	4,6	170	605

Initial pressure losses

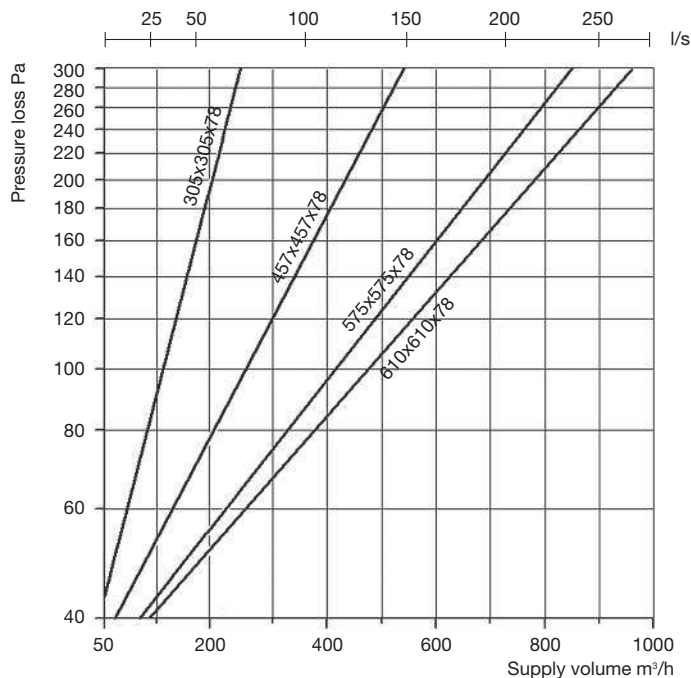

Initial pressure losses for U15 Ulpa filters with a depth of 130 mm for the sizes 1–4. Recommended final pressure loss 400 Pa.

Clean air diffusers

Diffusers for clean air diffusers:

- Swirl diffuser DA
- Swirl diffuser DS
- Swirl diffuser DFA

The diffuser

Three types of diffusers are available. Detailed technical data is included in the specification sheets. The diffuser is mounted onto the plenum box with a M6 screw.



Swirl diffuser DA
($n \leq 15 \cdot h^{-1}$)



Swirl diffuser DS
($n \leq 25 \cdot h^{-1}$)



Swirl diffuser DFA
($n \leq 60 \cdot h^{-1}$)

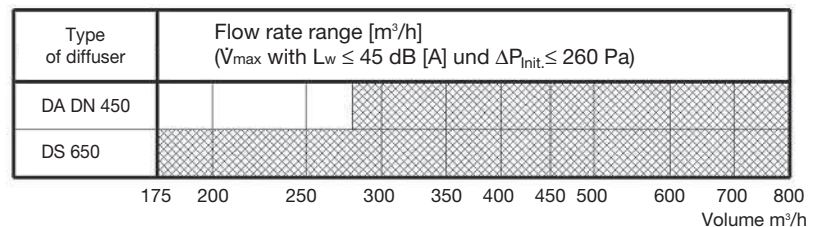
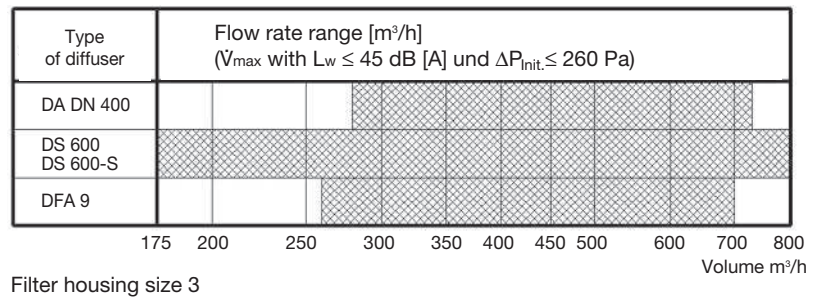
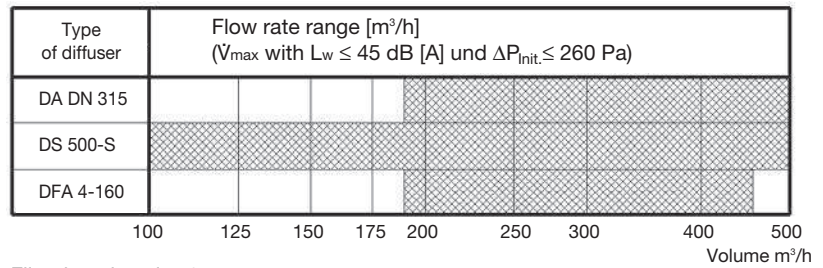
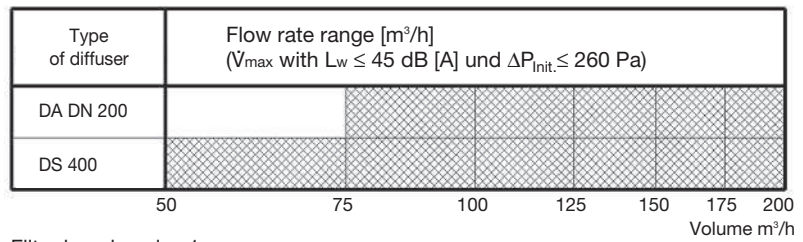

Flow rate range of DA, DS and DFA diffusers for housings 1, 2, 3 and 4

Clean air diffusers

Technical data RA Size 1

Dimensions
Noise level
Pressure loss

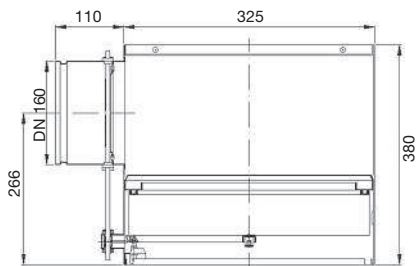

Dimensions of the filter housing size 1 with a 78 mm high filter.



RA size 1 with the swirl diffuser DA, DN 200.
Flange size 345–625 mm.



RA size 1 with the swirl diffuser DS, size 400.
Flange size 345–625 mm.

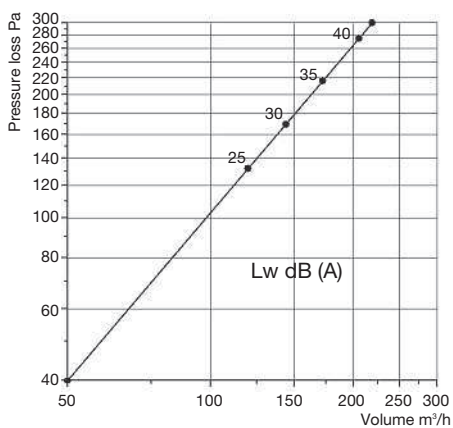

Noise level and pressure loss for filter housing, H13 filter and swirl diffuser DA, DN 200.

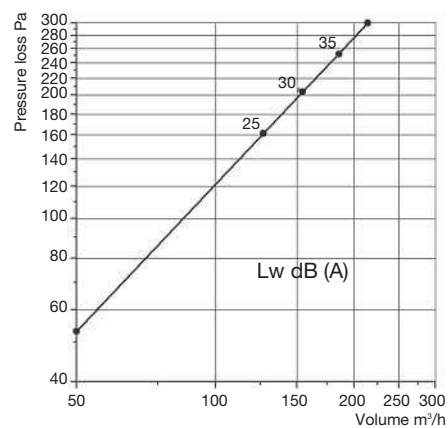

Noise level and pressure loss for filter housing, H13 filter and swirl diffuser DS, size 400.

Clean air diffusers

Technical data RA Size 2

Dimensions
Noise level
Pressure loss

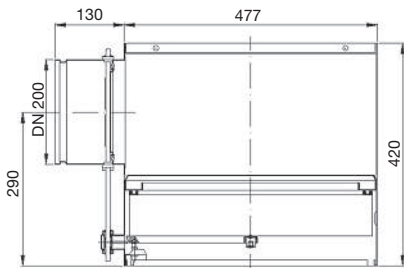

Dimensions of the filter housing size 2 with a 78 mm high filter.



RA size 2 with the swirl diffuser DA, DN 315. Flange size 500–625 mm.



RA size 2 with the swirl diffuser DS, size 500 S. Flange size 500–625 mm.



RA size 2 with the swirl diffuser DFA, 4/160. Flange size 500–625 mm.

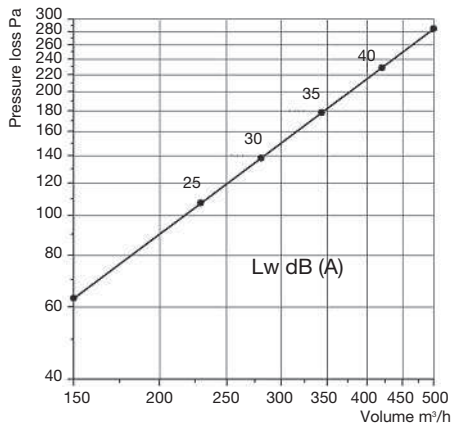

Noise level and pressure loss for filter housing, H13 filter and swirl diffuser DA, DN 315.

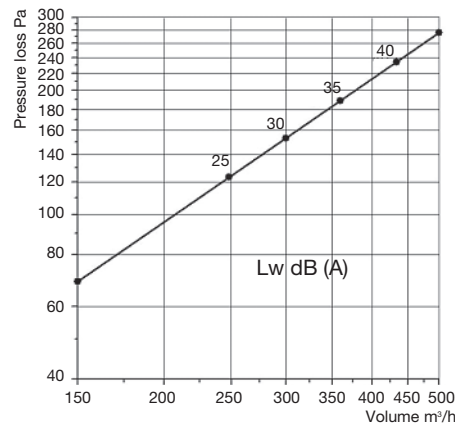

Noise level and pressure loss for filter housing, H13 filter and swirl diffuser DS, size 500 S.

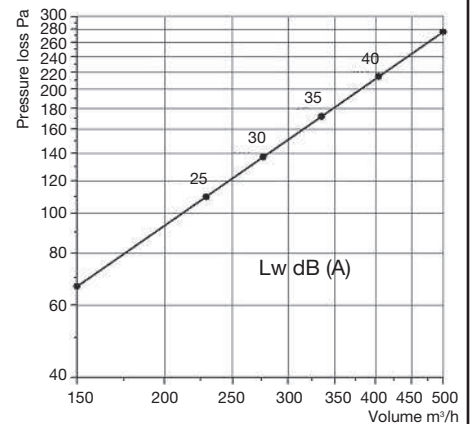

Noise level and pressure loss for filter housing, H13 filter and multi-outlet swirl diffuser DFA 4/160.

Clean air diffusers

Technical data RA Size 3

Dimensions
Noise level
Pressure loss

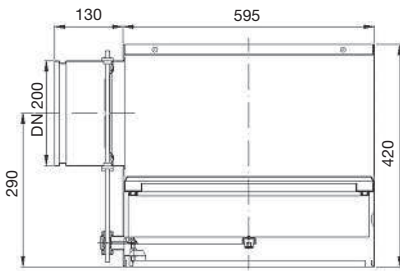

Dimensions of the filter housing size 3 with a 78 mm high filter.



RA size 3 with the swirl diffuser DA, DN 400. Flange size 600–625 mm.



RA size 3 with the swirl diffuser DS, size 600. Flange size 600–625 mm.



RA size 3 with the swirl diffuser DFA 9. Flange size 600–625 mm.

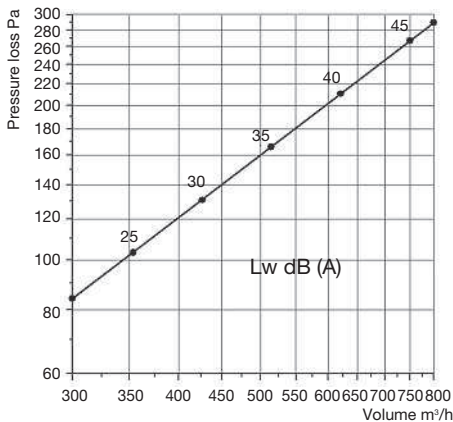

Noise level and pressure loss for filter housing, H13 filter and swirl diffuser DA, DN 400.

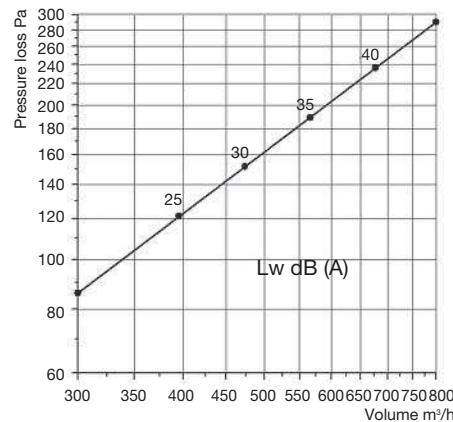

Noise level and pressure loss for filter housing, H13 filter and swirl diffuser DS 600.

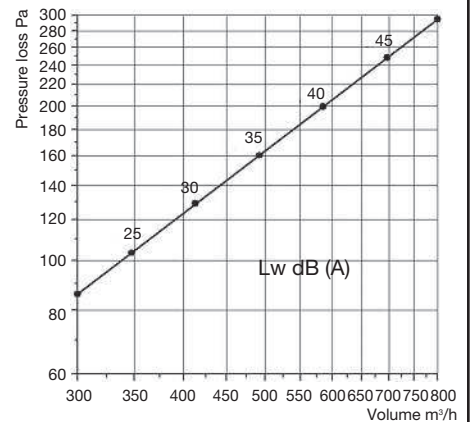

Noise level and pressure loss for filter housing, H13 filter and multi-outlet swirl diffuser DFA 9.

Clean air diffusers

Technical data RA Size 3

Dimensions
Noise level
Pressure loss

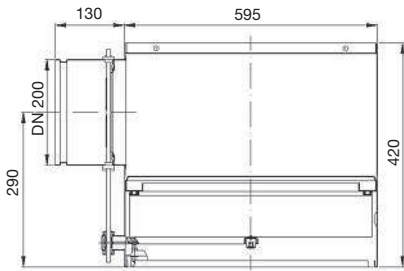

Dimensions of the filter housing size 3 with a 78 mm high filter, inlet spigot DN 200 (standard).

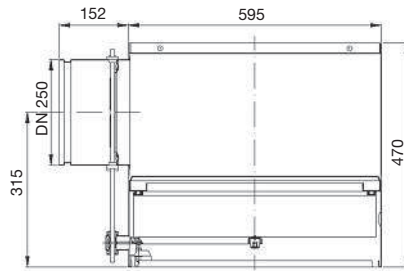

Dimensions of the filter housing size 3 with a 78 mm high filter, inlet spigot DN 250.



RA size 3 with the swirl diffuser DS, size 600 S. Flange size 600–625 mm.

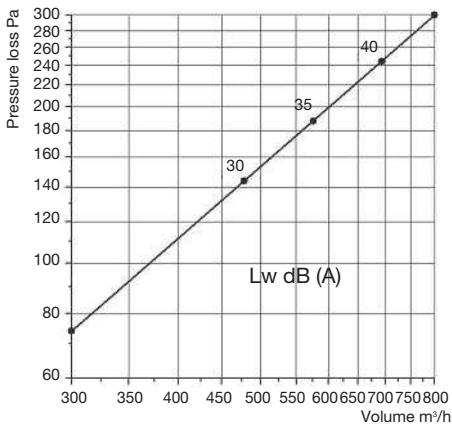

Noise level and pressure loss for filter housing, H13 filter and swirl diffuser DS, spigot DN 200.

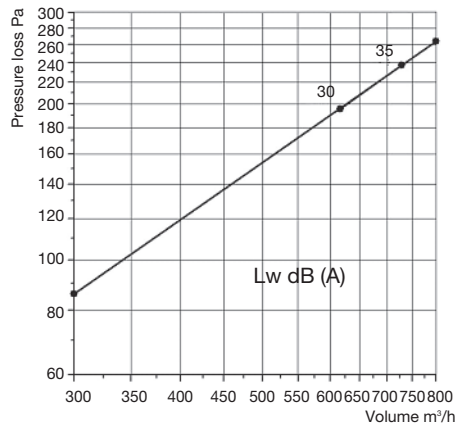

Noise level and pressure loss for filter housing, H13 filter and swirl diffuser DS 600 S, spigot DN 250.

Clean air diffusers

Technical data RA Size 4

Dimensions
Noise level
Pressure loss

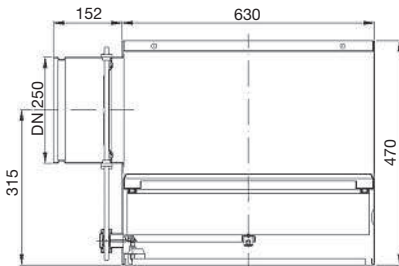

Dimensions of the filter housing size 4 with a 78 mm high filter.



RA size 4 with the swirl diffuser DA, DN 450. Flange size 650 mm.



RA size 4 with the swirl diffuser DS, size 650. Flange size 650 mm.

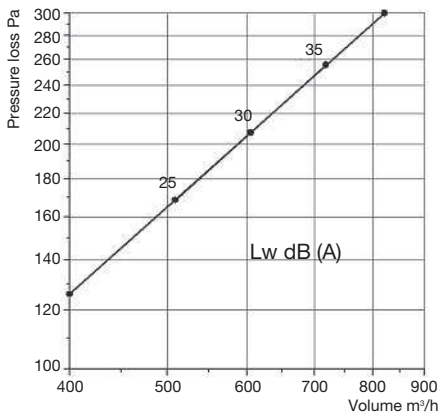

Noise level and pressure loss for filter housing, H13 filter and swirl diffuser DA, DN 450.

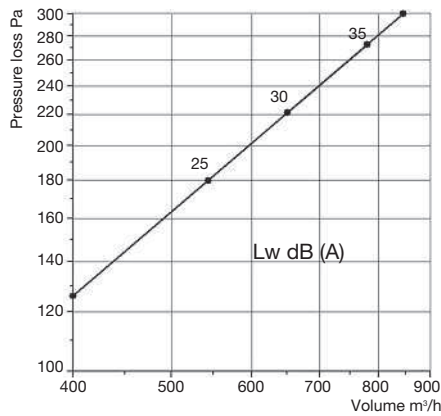

Noise level and pressure loss for filter housing, H13 filter and swirl diffuser DS 650.

Tender Text / Order Form

Item	Description	Units Pieces	Unit price	Total
	<p>Clean air diffuser RA along with filter housing, filter and diffuser. Steel plate filter housing, airtight in accordance with DIN 1946 Part 4, with decontaminable plastic coating, colour RAL 9010, optional with an airtight manual damper valve in accordance with EN 1751, class 4.</p> <p>Size</p> <p><input type="checkbox"/> 1 325 x 325 x 380 mm (the dimensions are valid for type A and B with a filter depth of 78 mm)</p> <p><input type="checkbox"/> 2 477 x 477 x 420 mm</p> <p><input type="checkbox"/> 3 595 x 595 x 420/470 mm</p> <p><input type="checkbox"/> 4 630 x 630 x 470 mm</p> <p>Inlet spigot</p> <p><input type="checkbox"/> Circular, vertical without a damper valve, DN</p> <p><input type="checkbox"/> Circular, horizontal without a damper valve, DN</p> <p><input type="checkbox"/> Circular, horizontal with a manual damper valve, DN</p> <p><input type="checkbox"/> Rectangular, width: height:</p> <p>Filter firm seat system</p> <p><input type="checkbox"/> Smooth flange for grooved test sealing (type A)</p> <p><input type="checkbox"/> Profile flange for flat sealing (type B)</p> <p><input type="checkbox"/> Special flange for gel sealing (type C)</p> <p>Measuring and testing connections</p> <p><input type="checkbox"/> Device to test the firm seat of the filter</p> <p><input type="checkbox"/> Manometer oil mist connection (inside)</p> <p><input type="checkbox"/> External connection for the inlet pressure</p> <p><input type="checkbox"/> External connection for the filter differential pressure</p> <p>Filter</p> <p>Filter class (DIN EN 1822-1 or 779)</p> <p>Filter height</p> <p><input type="checkbox"/> 78 mm (standard)</p> <p><input type="checkbox"/> mm</p> <p>Filter sealing</p> <p><input type="checkbox"/> Grooved firm seat test sealing</p> <p><input type="checkbox"/> Flat neoprene sealing</p> <p><input type="checkbox"/> Continuous polyurethane sealing</p> <p>Filter frame</p> <p><input type="checkbox"/> Wood (medium-density fibreboard)</p> <p><input type="checkbox"/> Aluminium</p> <p><input type="checkbox"/> Stainless steel</p> <p>Diffuser</p> <p><input type="checkbox"/> Swirl diffuser DA, DN</p> <p><input type="checkbox"/> Swirl diffuser DS, size</p> <p><input type="checkbox"/> Swirl diffuser DFA</p> <p>Material and surface of the diffuser</p> <p><input type="checkbox"/> Steel, coated to RAL 9010</p> <p><input type="checkbox"/> Stainless steel (1.4301), blasted</p> <p><input type="checkbox"/> Flange size: x</p> <p>Volume flow: m³/h</p> <p>Maximum noise level: dB (A)</p> <p>Initial pressure loss: Pa</p>			



CONTACTGEGEVENS

INTERLAND TECHNIEK

TIELENSTRAAT 17
5145 RC WAALWIJK

T +31 (0)416 317 830
E INTERLANDTECHNIEK@HCGROEP.COM
I WWW.INTERLANDTECHNIEK.NL

